

# Oil Diffusion Ejector Vacuum Pump PBL Series



PBL-04



PBL-10

ULVAC's oil diffusion ejector pumps are generally used in industrial processes to provide high pumping speed. They are particularly well-suited for use in metallurgy, plastic coating and chemical manufacturing, where large quantities of gas have to be pumped away as quickly as possible. With no moving parts, these pumps are rugged and extremely reliable. They are very much like standard oil diffusion pumps, but are optimized to work at higher inlet pressures.

### Features

- These pumps have maximum pumping speed at  $10^{-1}$  Pa level.
- Stainless steel is used for the pump bodies of Model PBL-02 and PBL-04 in order to minimize outgassing of the pumps, eliminate corrosion and to ensure a long operating lifetime of the pump.
- The PBL Series are particularly well-suited for the use as an intermediate pump between an oil rotary pump, a mechanical booster pump and oil diffusion pump.
- The larger capacity pumps (PBL-06 - PBL-20) have the heaters directly immersed in the operating fluid for maximum thermal efficiency.

### Working Principle and Structure

### External Dimension Diagram (unit: mm)

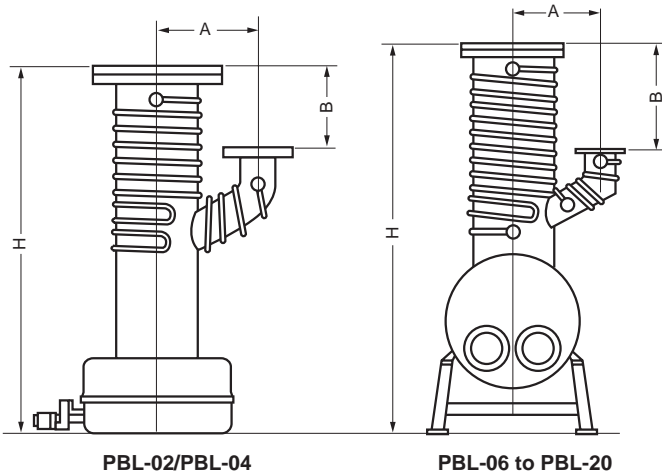

Model	PBL-02	PBL-04	PBL-06	PBL-10	PBL-14	PBL-20
Dimensions						
H	463	526	975	1325	1687	2344
A	100	150	200	300	340	510
B	70	110	152	346	548	444

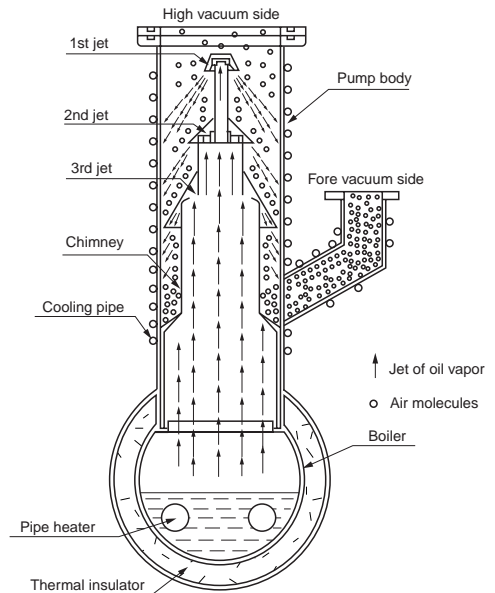

The oil diffusion ejector pump consists of a pump body, heater and 3-stage jet stack assembly. The working fluid is heated in the boiler, vaporized and ejected out of each stage of the jet stack at high speed. Gas molecules on the high vacuum (inlet) side of the pump are captured in the jet vapor stream and are transported from the upper to the lower jet stages which compresses them in the process. These pumped gasses are then exhausted through the outlet port to the backing pump. The vapor stream from the jet stack is cooled and condensed on the inner walls of pump housing and returned to the boiler.

Specifications

- Standard accessories
- Working fluid for one charge (ULVOIL B-50)
- One set of gaskets (Material: NBR)

- One set of hose nipples for cooling water connection
- Water cooling baffle, flange, bolts and nuts are optional.

Item	Model	PBL-02	PBL-04	PBL-06	PBL-10	PBL-14	PBL-20
Pumping speed	L/s	80	300	600	1800	4000	8000
Ultimate pressure	Pa	$2.7 \times 10^{-2}$	$2.7 \times 10^{-2}$	$2.7 \times 10^{-2}$	$2.7 \times 10^{-2}$	$2.7 \times 10^{-2}$	$2.7 \times 10^{-2}$
Maximum allowable fore pressure (critical backing pressure)	Pa	27	40	80	40	90	40
Power required	kW	200 V single phase 0.44	200 V single phase 1.8	200 V three phase 4.0	200 V three phase 8.0	200 V three phase 11.0	200 V three phase 18.0
Heater		Cartridge heater	Heater plate	Pipe heater 2 kW x 2	Pipe heater 4 kW x 2	Pipe heater 5.5 kW x 2	Pipe heater 6 kW x 3
Fluid capacity	L	0.1	0.6	7.5	18	36	90
Working fluid		ULVOIL® B-50	ULVOIL® B-50	ULVOIL® B-50	ULVOIL® B-50	ULVOIL® B-50	ULVOIL® B-50
Water consumption	L/min	1.5	5	8	12	18	25
Inlet port diameter	B	2	4	6	10	14	20
Exhaust port diameter	B	$\frac{3}{4}$	$1\frac{1}{2}$	2	3	4	8
Weight	kg	6	17	86	198	313	495
Recommended fore pump*2 (Backing pump)		D-330K VD301 PVD-360	PKS-016 VS1501	PKS-030 VS2401	PKS-070 (PRC-006A +PKS-030) (PRC-006A +VS1501)	PRC-012A +PSK-030 PRC-012A +VS1501	PMB-040B +PKS-070 (PMB-024C +PSK-070)

\* 1 Ultimate pressure is measured with an ion gauge and attainable when the cooling water temperature is 20 °C.

\* 2 Fore pumps are selected corresponding to the maximum throughput Q. In practice, however, fore pumps having a large capacity are often used to shorten rough time of the chamber being pumped, unless a separate backing pump is to be used only for the oil diffusion pump.

Pumping Speed Curve

