

Oil Diffusion Vacuum Pump PFL Series



PFL-22

Close attention to material selection and manufacturing techniques ensure reliable operation and a very low cost of ownership for the PFL Series.

Features

- Excellent pumping speed
- Low back-streaming of the operating fluid
- Minimized power required and fluid capacity to ensure low operating cost
- Easy maintenance
- Reliable pump body construction

Working Principle and Structure

The oil diffusion pump consists of a pump body, boiler heater and 3-stage fractionating jet stack assembly. The working fluid (oil) is heated in the boiler, vaporized and streams out of each stage of the jet stack at high speed. Gases on the high vacuum (inlet) side of the pump are captured in the jet vapor by diffusion, and are carried from upper to the lower jet stages which compresses them in the process. These pumped gasses are then exhausted through the outlet port to the fore pump. The vapor stream from the jet stack is cooled and condensed on the inner walls of pump body, and returned to the boiler. By repetition of this process, evacuation is accomplished. The weir plate provided in the boiler permits return and recirculation of the working fluid, allowing the fractional distillation of the fluid to be a continuous process. (High vapor pressure components in the working fluid are evaporated at the outer zone of the pump housing, while low vapor pressure components are evaporated at the inner zone.)

Structure

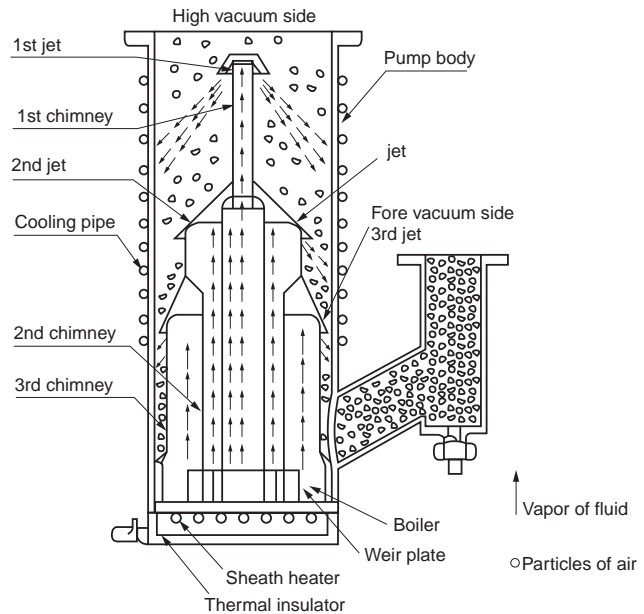

External Dimension Diagram (unit: mm)

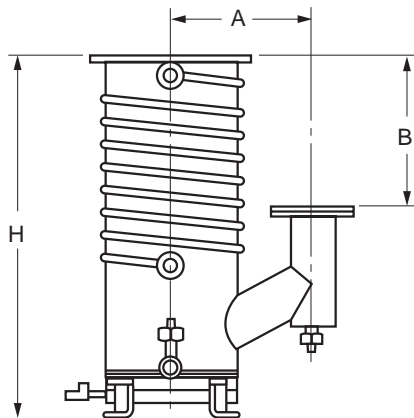

Model	PFL-22	PFL-36	PFL-52
Dimensions			
A	480	725	1000
B	630	1022	2000
H	1330	1732	2845

Accessories

Standard accessories

- One charge of working fluid (ULVOIL D-11)
- One set of gaskets
- One set of hose nipples for cooling water connection
- Water cooling baffle, flange, bolts and nuts are optional.

Specifications

Item \ Model		PFL-22	PFL-22 (TM)	PFL-36	PFL-52
Pumping speed	L/s	10,000	10,000	34,000	70,000
Ultimate pressure*1	Pa	3×10^{-4}	3×10^{-4}	3×10^{-4}	3×10^{-4}
Maximum allowable fore pressure (Critical backing pressure)	Pa	16	16	6.7	16
Power required	kW	Three phase 200 V 8	Three phase 200 V 10	Three phase 200 V Start 22, Normal 11	Three phase 200 V Start 45, Normal 30
Heater		Heater plate	Heater plate	Heater plate	Heater plate
Fluid capacity	L	5	5	13	27
Working fluid*2		ULVOIL® D-11	ULVOIL® D-11	ULVOIL® D-11	ULVOIL® D-11
Cooling water consumption	L/min	12	12	38	50
Inlet port diameter	B	22	22	36	52
Exhaust port diameter	B	6	8	10	14
Weight	kg	290	290	650	1400
Recommended fore pump*3		PMB-040B+PKS-070 (PMB-012C+PKS-030)	PMB-040B+PKS-070 (PMB-012C+PKS-030)	PMB-040B+PKS-070 (PMB-012C+PKS-070) (PMB-024C+PKS-070)	PMB-060B+PKS-070 x 2 (PMB-024C+PKS-070)

* 1 Ultimate pressure is measured with an ionization vacuum gauge.

* 2 Several kinds of working fluid are available.

* 3 Fore pumps are selected corresponding to maximum throughput Q. In practice, however, mechanical booster pumps or oil rotary pumps having a larger capacity as fore pumps are generally used for shortening the rough time of the vacuum chamber being evacuated. Alternatively, a smaller separate backing pump can be used just for the diffusion pump.

Pumping Speed Curve

